

Carbon Dioxide Solubility - Student Activity

How does temperature affect solubility?

The ocean is known as a carbon sink. It has been calculated that the ocean stores around 38,000 gigatons of carbon. This is 16 times as much carbon as the biosphere and 60 times as much as the atmosphere (World Ocean Review, 2010). The ocean absorbs carbon from the atmosphere. With global ocean temperatures rising, it is important to know how the oceans will cope and if they will still be able to absorb carbon dioxide as effectively as they have been.

When effervescent tablets are placed in water a chemical reaction happens and carbon dioxide gas is created. This is what makes the water fizz. The warmer the water the more it will fizz, as less carbon dioxide can be dissolved.

Aim To investigate the effect of water temperature on how much CO₂ it can dissolve.

Materials per group

- A large test tube/ boiling tube with a bung with piping in it (diagram below)
- Measuring cylinder
- Ice cream tub
- Effervescent tablet e.g. Alka-Seltzer
- Stop watch

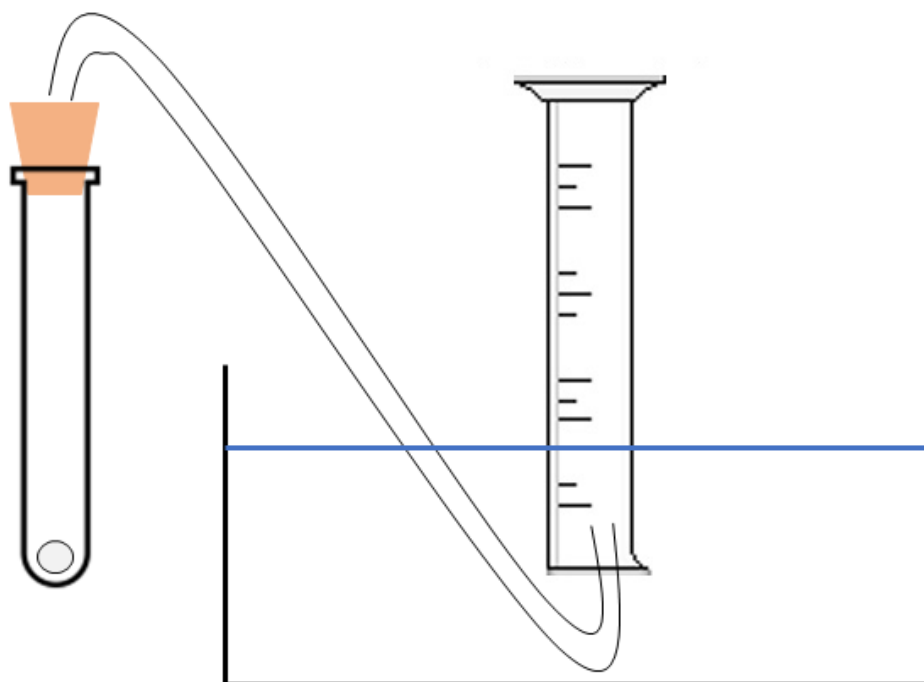

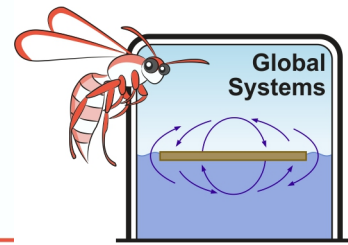

Carbon Dioxide Solubility - Student Activity

Method

1. Half fill the ice cream tub with water.
2. Fill the measuring cylinder with water and invert it in the ice cream tub so it remains full of water.
3. Feed the piping into the measuring cylinder.
4. Fill the test tube with cold water and add the tablet, placing the bung on as quickly as possible
5. Start the timer.
6. After 30 seconds measure how much water has been displaced in the measuring cylinder.
7. Repeat the investigation using warm water in the test tube.

Results/Observations

What did you observe?

Much more water was displaced from the measuring cylinder in 30 seconds when warm water was used.

Conclusion

What conclusion can you draw from the investigation?

The warm water was unable to dissolve and store as much carbon dioxide as the cold water.

Discussion

Explain what affect a warming ocean will have on the amount of CO₂ it is able to dissolve into solution? A warmer ocean will be unable to dissolve as much carbon dioxide as a colder ocean, meaning there will be more in the atmosphere.

How can this activity be improved?

You could investigate a wider range of temperatures and create a graph showing temperature against the amount of CO₂ released.

Reference

World Ocean Review, The oceans – the largest CO₂ reservoir, 2010. Accessed at, <https://worldoceanreview.com/en/wor-1/ocean-chemistry/co2-reservoir/>, on 10/7/2019